

Contrasting Evolutionary Patterns in *Drosophila* Immune Receptors

Francis M. Jiggins, Kang-Wook Kim

Institute of Evolutionary Biology, School of Biological Sciences, University of Edinburgh, West Mains Road, Edinburgh EH9 3JT, Scotland

Received: 6 January 2006 / Accepted: 28 August 2006 [Reviewing Editor: Dr. Willie Swanson]

Abstract. Vertebrate immune system molecules that bind directly to parasites are commonly subject to strong directional natural selection, probably because they are engaged in an evolutionary arms race with parasites. We have investigated whether similar patterns of evolution are seen in components of the *Drosophila* immune system that bind parasite-derived molecules. In insects, TEPs (thioester-containing proteins) function as opsonins, binding to parasites and promoting their phagocytosis or encapsulation. The *Drosophila melanogaster* genome encodes four TEPs, three of which are upregulated after an immune challenge. We report that two of these three *Drosophila* genes evolve rapidly under positive selection and that, in both *TepI* and *TepII*, the “bait-like region” (also known as the variable region) shows the strongest signature of positive selection. This region may be the site of proteolytic cleavage that leads to the activation of the molecule. It is possible that the proteolytic activation of TEPs is a target of host-parasite coevolution, with parasites evolving to prevent proteolysis, which in turn favors mutations in the bait-like region that restore the response. We also sequenced three gram-negative binding proteins (GNBPs) and two immune-induced peptides with strong homology to the GNBPs. In contrast to the *Tep* genes, the *GNBP* genes are highly conserved. We discuss the reasons why different components of the immune system have such different patterns of evolution.

Key words: *Drosophila* — Gram-negative binding protein — Thioester-containing protein — Immunity

Introduction

Vertebrate immune system receptors such as MHC molecules and immunoglobulins are very specific in the parasite-derived epitopes that they bind to. Furthermore, different alleles and copies of the MHC and immunoglobulin genes encode proteins that bind to a diverse range of different epitopes. This diversity of recognition molecules has arisen through positive Darwinian selection, as the regions of these genes that determine the binding specificity of the receptors have an excess of nonsynonymous relative to synonymous mutations (Hughes and Nei 1988; Tanaka and Nei 1989). This is believed to result from either overdominant or frequency-dependent selection enhancing the diversity of receptor specificities in the population.

The innate immune system is another important component of vertebrate immunity and is the only immune response available to invertebrates. Innate immunity relies entirely on germline-encoded receptors, unlike the adaptive immune system, which generates an enormous repertoire of receptors through somatic mutation and recombination. Despite this limitation, the innate immune response can recognise and eliminate a broad array of pathogens and parasites. This is thought to be the result of pathogens being recognized by highly conserved “pathogen-associated molecular patterns” and then eliminated using effector molecules that act on other

Correspondence to: Francis M. Jiggins; email: Francis.Jiggins@ed.ac.uk

highly conserved targets (Medzhitov and Janeway 1997). For this reason, innate immune system receptors are believed to recognise a far lower diversity of molecules than MHC molecules or immunoglobulins.

It is therefore of interest to compare the molecular evolution of innate immune system molecules that bind directly to pathogens with the patterns observed in MHC and immunoglobulin molecules. It is possible that similar selective forces act on both classes of molecules, and positive selection may act to diversify or change the binding specificity of innate immune system receptors. However, if innate immune system molecules recognize highly conserved pathogen targets, there may be little or no selection to either change or diversify their specificities.

Previous studies on the molecular evolution of two families of *Drosophila* immune receptors have produced contrasting results. The first of these protein families are the peptidoglycan recognition proteins (PGRPs), some of which bind to pathogens and initiate the production of antimicrobial peptides. These proteins were found to evolve slowly under predominantly purifying selection (Jiggins and Hurst 2003). In contrast, several scavenger receptors, which bind to pathogens and play a role in their phagocytosis, evolve rapidly under positive selection (Lazzaro 2005). In this study we investigated two further classes of immune receptors that are believed to bind directly to pathogens, the thioester-containing proteins (TEPs) and the gram-negative bacteria-binding proteins (GNBPs). This will provide a fairly complete picture of the molecular evolution of *Drosophila* proteins thought to bind to the surface pathogens and elicit an immune response.

The first family of genes we studied are the TEPs (Blandin and Levashina 2004). In vertebrates, this family includes two key components of the immune system, the α_2 -macroglobulins and complement factors C3, C4, and C5. The α_2 -macroglobulins are protease inhibitors. They are cleaved by proteases released by pathogens, resulting in a conformational change in the α_2 -macroglobulin that entraps the protease, inhibiting its action and ultimately leading to its endocytosis. The complement factors C3 and C4 are also activated by proteolytic cleavage to expose their reactive thioester bond. In this case, however, the activating proteases are the host-derived convertase complex. The larger cleavage product then acts as an opsonin, covalently binding to the pathogen and promoting phagocytosis. The proteolytic cleavage also produces a smaller fragment (anaphylatoxin) whose functions include the attraction of macrophages.

TEPs are also an important component of insect immune systems (Blandin and Levashina 2004). The most detailed functional studies of insect TEPs have been on *aTepI* in *Anopheles* mosquitoes. Following infection with bacteria, the *aTepI* gene is upregulated

and its protein product proteolytically cleaved (Blandin and Levashina 2004). It then binds to the bacteria through the thioester bond and functions as an opsonin, promoting the phagocytosis of the pathogen. *aTepI* also binds to *Plasmodium* parasites, and knocking down the expression of the gene by RNAi prevents melanization of the parasites (Blandin et al. 2004). Intriguingly, the sequence of the 280-amino acid-long C3d domain of *aTepI* is very variable, and it has been postulated that this may be responsible for variation in the ability of mosquitoes to transmit malaria (Blandin et al. 2004).

The genome of *Drosophila melanogaster* contains four *Tep* genes, three of which (*TepI*, *TepII*, and *TepIV*) are strongly upregulated following immune challenge (Lagueux et al. 2000). The function of these genes has been investigated using RNAi in cell culture, and it was found that *TepII* and *TepIII* are required for the efficient phagocytosis of *E. coli* and *Staphylococcus aureus*, respectively (Stroschein-Stevenson et al. 2006). A gene called *Mcr*, which is related to the *Tep* genes but lacks the thioester motif, was required for phagocytosis of the fungal pathogen *Candida albicans* (Stroschein-Stevenson et al. 2006). Therefore, different members of this protein family target different pathogens and promote their phagocytosis. None of the *Drosophila Tep* genes have 1:1 orthologues in the *Anopheles* genome, and the three immune-upregulated genes have probably arisen by gene duplication in the *Drosophila* lineage (Christophides et al. 2002).

The hypervariable or bait-like region lies near the center of the *Tep* coding sequence in *D. melanogaster*. The corresponding region in vertebrate TEPs encodes the bait region of α_2 -macroglobulins and the anaphylatoxin fragment of complement protein C3 (Lagueux et al. 2000). In α_2 -macroglobulins, interspecific sequence variation in this region causes changes in the range of proteases that cleave the α_2 -macroglobulin (Sottrup-Jensen et al. 1989). In *D. melanogaster*, the amino acid sequence of this region is poorly conserved in comparisons both with TEPs in other animals and between paralogous *Tep* genes in the genome (Lagueux et al. 2000). Furthermore, alternative splicing of the *TepII* transcript can result in proteins with five different bait-like regions (Lagueux et al. 2000), suggesting that sequence variation in this region is functionally important. In the crustacean *Daphnia*, this region of a *Tep* gene evolves rapidly under positive selection (Little et al. 2004). Therefore, the bait-like region is a candidate target of host-parasite coevolution.

The second family of proteins that we investigated is the GNBPs. These proteins have sequence similarities to bacterial glucanases, and probably represent a case of either horizontal gene transfer or convergent evolution (Ferrandon et al. 2004; Lee

et al. 1996). Although they do not show enzymatic activity, various GNBP s are able to bind to fungal β -1,3-glucans, bacterial lipopolysaccharides, and/or bacterial lipoteichoic acid (Dimopoulos et al. 1997; Kim et al. 2000). Two *Drosophila* GNBP s have been shown to function as pattern recognition molecules. GNBP1 together with another pattern-recognition molecule, called PGRP-SA, is required to activate the Toll pathway in response to infection by gram-positive bacteria (Gobert et al. 2003). The Toll pathway leads to the production of antimicrobial peptides, and loss-of-function mutants in *GNBP1* are very susceptible to infection by gram-positive bacteria. It has also been reported that loss-of-function mutants in another gene, *GNBP3*, are sensitive to fungal infection, although the primary data to support this have yet to be published (Ferrandon et al. 2004).

The *Drosophila* genome contains three full-length *GNBP* genes (*GNBP1*, *GNBP2*, and *GNBP3*), none of which is upregulated following infection (De Gregorio et al. 2001; Irving et al. 2001). There are also two genes (CG13422 and CG12780) that are very similar to the N-terminal part of the GNBP s and are upregulated following bacterial infection (De Gregorio et al. 2001; Irving et al. 2001). One of these (CG13422) is also upregulated following fungal infection (De Gregorio et al. 2001).

In this study we have tested whether natural selection drives causes rapid evolution of these proteins. Polymorphism data from *Drosophila simulans* for *GNBP1* and part of *TepI* have previously been collected by Schlenke and Begun (2003). Neither of these genes showed individual departures from neutrality (Schlenke 2003, Supplementary Material). In this paper we present a larger and more comprehensive dataset on these two gene families from the closely related species *D. melanogaster*.

Methods

Isofemale *D. melanogaster* lines that had originally been collected in the Netherlands or Gabon by Peter Andolfatto and Bill Ballard were supplied by Penny Haddrill. The appropriate chromosomes were made isogenic using standard crosses to balancer stocks (SM1 and TM6). Analysis of this preliminary dataset showed that the bait-like region of *TepII* evolved extremely rapidly but did not show unequivocal evidence of positive selection. Therefore, we increased our dataset for this gene by sequencing eight alleles of from Kenyan isofemale lines of *D. simulans* that had been inbred by sib mating for nine generations.

Population genetic analyses can be confounded by the presence of chromosomal inversions in the population because they suppress recombination. Therefore, inversions may introduce strong haplotype structure into the dataset. Furthermore, it is well-known that genes within inversions are often under strong selection and so selection, even on loci far from the gene of interest, may alter patterns of polymorphism in the target gene (Powell 1997). For this reason we only used inversion-free chromosomes for sequencing. These were identified by crossing the isogenic chromosomes to an

inversion-free stock and checking the salivary gland chromosomes for the presence of inversion loops.

All of the *Tep* genes are on chromosome arm 2L. In the sample from Gabon, 8 of 21 2L chromosome arms had inversions, and 10 inversion-free lines were retained for sequencing. *GNBP1*, *GNBP2*, and *GNBP3* are all on chromosome arm 3L. Unfortunately, we were unable to obtain a sufficient number of homozygous lines for this chromosome and therefore sequenced the *GNBP* genes from the Netherlands lines. In the Netherlands lines, all 16 of the 3L chromosome arms inspected were inversion-free, and 12 of these were retained for sequencing. The two shorter GNBP s (CG13422 and CG12780) are on chromosome arm 2R. Of 14 Netherlands 2R chromosome arms inspected, 13 were inversion-free. *D. melanogaster* is thought to have originated in Africa and passed through a population bottleneck during the colonization of Europe (David and Capy 1988). This should not affect patterns of interspecific divergence. The out-of-Africa range expansion had little effect on autosomal genetic diversity (Andolfatto 2001), but care should nonetheless be taken when comparing the European *GNBP* and African *Tep* polymorphism data.

We sequenced 12 alleles of all five *GNBP* genes and 10 alleles of the three *Tep* genes that are upregulated following infection (*TepI*, *TepII*, and *TepIV*). We sequenced the entire coding region and introns of the five *GNBP* genes. The *Tep* genes are longer than the *GNBP* genes, so we only sequenced the regions shown in Fig. 1. Sequence data from this article have been deposited with the EMBL/GenBank data libraries under accession numbers AJ973199–AJ973208, AJ973615–AJ973634, and AM050187–AM050254. We also analyzed sequences of the *Tep* genes obtained by Blast searching the annotated genome sequences of several *Drosophila* species (Smith 2004; Wilson 2004). The genome assemblies used were *D. melanogaster* Flybase release 4.0, *D. pseudobscura* Flybase release 1.0, *D. simulans* Langley Group assembly 29/9/2004, *D. yakuba* Langley Group assembly 22/5/2004, *D. mojavensis* Agencourt Bioscience Corporation assembly 6/12/2004, *D. virilis* Agencourt assembly 29/10/2004, *D. erecta* Agencourt assembly 28/10/2004, and *D. annanasae* Agencourt assembly 6/12/2004. We checked that all the sequences of a given gene were reciprocal best tBLASTn hits (Altschul et al. 1997). We also aligned all the inferred amino acid sequences of the *Tep* genes (excluding the most variable regions) and reconstructed a neighbor-joining tree (data not shown). In all cases, the sequences of each *Tep* gene from different species formed a monophyletic group. Furthermore, the relationships within each of these clades were the same as the known phylogeny of different species of flies. All analyses were based on ClustalW alignments of the nucleotide sequence that were corrected by eye to account for the amino acid sequence.

We compared the K_a/K_s ratio of the *Tep* and *GNBP* genes with genome-wide estimates of K_a/K_s between *D. simulans* and *D. melanogaster*. The genes were selected for analysis if all exons were identifiable as unique best reciprocal BLAST hits between known *D. melanogaster* genes and the April 2005 release of the *D. simulans* genome. Those in which the *D. simulans* data were not valid coding sequence were rejected. CodeML (PAML) (Yang 1997) was used to provide maximum-likelihood estimates of K_a/K_s for all genes (runmode = -2). Because the K_a/K_s ratio has both a higher variance and a higher mean in short genes, we only included genes that had coding sequences of 1 kb or more, resulting in a final set of 4558 genes.

Functionally important regions of the genes are shown in Fig. 1. The location of the bait-like region (also known as the variable region) was taken from Fig. 1 of Lagueux et al. (2000) when it fell at exon boundaries. When this was not the case, the end of the bait-like region was defined as the end of Block D (Lagueux et al. 2000). The starts of the bait-like regions within exons were identified by aligning the amino acid sequence of the four genes. The C3d-like domain was predicted by aligning the amino acid

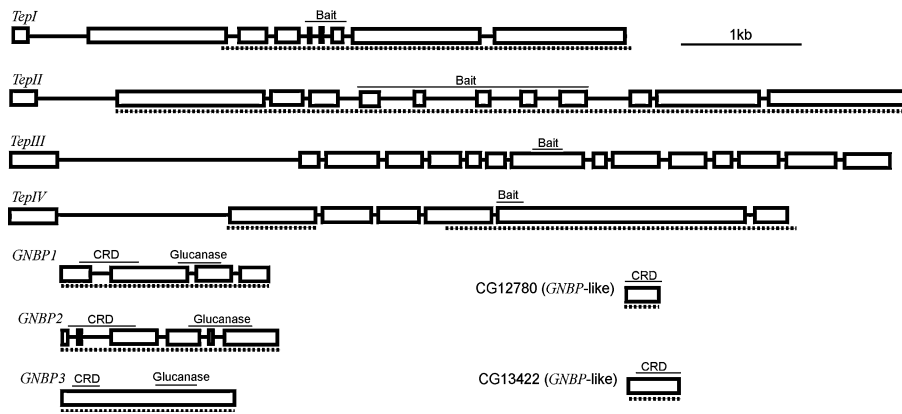

Fig. 1. The arrangement of *Tep* and *GNBP* introns and exons. The region sequenced is indicated by a dashed line below each gene. The location of the bait-like region, CRD-like domain (carbohydrate recognition domain), and glucanase-homology domain are marked above.

sequences of the *Drosophila* genes with the C3d-like region of *aTepI* of *Anopheles* (Blandin et al. 2004).

The full-length *GNBP* transcripts encode a signal peptide followed by a carbohydrate-recognition domain, a link region, the glucanase-homology domain, and, finally, a C-terminal section (Fabrick et al. 2004) (Fig. 1). The signal peptides were predicted using the program SignalP 3.0 (Bendtsen et al. 2004). The location of the carbohydrate recognition domain (CRD) was predicted by aligning the amino acid sequence with this domain from *Bombyx mori*, where it has been identified experimentally (Ochiai and Ashida 2000). The glucanase homology domain was taken from Kim et al. (2000).

We tested for heterogeneity in the polymorphism-to-divergence ratio across the gene sequences using the program DNAslider (McDonald 1996, 1998). This method first classifies variable sites into intraspecific polymorphisms or interspecific fixed differences. Following the recommendation of McDonald (1998), we used the three different statistics (the Kolmogorov-Smirnov statistic, the number of runs, and the mean sliding *G*) for detecting heterogeneity, as each is most powerful in different situations. The significance of these statistics was assessed by generating 1000 replicate datasets by coalescent simulation. These simulations were conditioned on the recombination rate *R*. In *D. simulans* and *D. melanogaster* there is no recombination in males, and therefore for autosomal genes $R=2Nc$ (where *N* is the effective population size and *c* the crossing-over rate/bp/generation in females). We assumed that in *D. simulans* $N = 2 \times 10^6$ and in *D. melanogaster* $N = 10^6$ (Andolfatto and Przeworski 2000). We used the estimate of *c* in *D. melanogaster* obtained by Marais et al. (2003) using the polynomial method of Hey and Kliman (2002). We conservatively assumed the same value of *c* for *D. simulans*. The resulting estimates of *R* in *D. melanogaster* were 0.02826 for *TepI*, 0.09006 for *TepII*, 0.00204 for *TepIV*, 0.07066 for *GNBP3*, 0.01266 for *GNBP2*, 0.01266 for *GNBP1*, 0.02472 for *CG12780*, and 0.07726 for *CG13422*.

The statistical significance of the rate of nonsynonymous substitutions being higher than the rate of synonymous substitutions ($K_a > K_s$) was estimated by simulating 50,000 replicate datasets based on the Comeron (1995) model of nucleotide substitution using the program K estimator. The maximum likelihood analysis of K_a/K_s ratios was performed using the program PAML (Yang 1997). This analysis was based on published phylogenies of these species (((melanogaster,simulans),(yakuba,erecta)),ananassae),pseudobscura),(mojavensis,virilis)) (Ko et al. 2003; Powell 1997). Most population genetic analyses were implemented with the program DNAsp (Rozas and Rozas 1999). The null distributions of statistics describing the frequency distribution of mutations were obtained from 1000 coalescent simulations conditioned on θ and the recombination rates described above.

Results

Tep Interspecific Divergence

TepI is one of the most rapidly evolving genes in the *Drosophila* genome. The K_a/K_s ratio between the *D. melanogaster* and the *D. simulans* *TepI* sequences was 0.71, which is among the highest 0.5% of *Drosophila* genes over 1 kb long. *TepII* has a K_a/K_s ratio of 0.23, which is in the top 13th percentile of our genomic sample. *TepIV* evolves slightly slower ($K_a/K_s=0.17$) and falls in the highest 21st percentile. *TepIII* evolves slower than the genome average ($K_a/K_s=0.06$; 60th percentile).

TepI also evolves rapidly compared to other immune-related genes. In a sample of 64 immunity genes of all lengths, only an antimicrobial peptide expressed in the male reproductive tract, called andropin, has a higher K_a/K_s ratio. In this list, the K_a/K_s ratios of *TepII*, *TepI*, and *TepIII* had the 13th, 24th, and 49th highest K_a/K_s ratios, respectively.

The differences in the K_a/K_s ratios both among the four *Tep* genes and between the *Tep* genes and the rest of the genome are largely accounted for by differences in the nonsynonymous substitution rate (K_a ; Table 1). In contrast, the divergence at synonymous sites (K_s) is less heterogeneous across genes and gene regions (Table 1). Furthermore, these estimates of K_s are similar to the genome average in our comparison of *D. simulans* and *D. melanogaster* (unweighted mean in our dataset of 4558 genes, $K_s=0.12$). Therefore, the high nonsynonymous substitution rate is not due to increased mutation rates in the *Tep* genes but results from either positive selection or low selective constraints on the protein sequence.

As discussed in the Introduction, we had an a priori prediction that the bait-like region might be the target of antagonistic coevolution with parasites. In all three immune-upregulated genes, this region has a higher nonsynonymous substitution rate than

Table 1. Estimated number of nonsynonymous (K_a) and synonymous (K_s) substitutions per site between the *D. melanogaster* and *D. simulans* *Tep* and *GNBP* genes

Gene	Region	No. codons	K_a	K_s	K_a / K_s	$p (K_a/K_s > 1)$
<i>TepI</i>	Bait	62	0.160	0.035	4.57	<0.001
	Nonbait	1299	0.073	0.109	0.67	
<i>TepII</i>	Bait	263	0.086	0.085	1.01	n.s.
	Nonbait	1346	0.028	0.130	0.22	
<i>TepIII</i>	Bait	72	0.000	0.110	0.00	
	Nonbait	1360	0.007	0.118	0.06	
<i>TepIV</i>	Bait	52	0.045	0.148	0.30	
	Nonbait	1406	0.016	0.080	0.20	
CG12780	CRD	300	0.032	0.145	0.22	
CG13422	CRD	387	0.015	0.155	0.10	
	Other	69	0.087	0.048	1.81	
<i>GNBP1</i>	CRD	312	0.004	0.100	0.04	n.s.
	Glucanase	351	0.008	0.127	0.06	
	Other	807	0.012	0.131	0.09	
<i>GNBP2</i>	CRD	288	0.015	0.194	0.08	
	Glucanase	363	0.003	0.184	0.02	
	Other	732	0.021	0.129	0.16	
<i>GNBP3</i>	CRD	312	0.009	0.041	0.22	
	Glucanase	351	0.004	0.129	0.03	
	Other	807	0.016	0.114	0.14	

Note. CRD, carbohydrate recognition domain; glucanase, glucanase homology domain. The “nonbait” region includes the entire protein outside the bait region. The genetic distances and probability that $K_a/K_s > 1$ were estimated following Comeron (1995).

the rest of the gene, while in *TepIII* it is highly conserved (Table 1). In *TepI*, K_a is significantly higher than K_s in the bait-like region ($p < 0.001$; Table 1), and this result holds after correction for multiple tests ($p < 0.008$). This provides strong evidence that positive selection has acted on this region during the divergence of these species. The *TepII* bait-like region has $K_a/K_s = 1$, which suggests either that this region evolves neutrally or that some sites are under positive selection.

It is possible that positive selection is acting on parts of the gene other than the bait-like region, so we also conducted a sliding-window analysis of the K_a/K_s ratio along the length of the genes (Fig. 2). This confirms that the bait-like regions of *TepI* and *TepII* have the highest K_a/K_s ratios. In the *Anopheles gambiae aTepI* gene, the C3d-like domain is very polymorphic (Blandin et al. 2004). This domain surrounds the thioester active site, and it has been suggested that these polymorphisms may have important effects on the binding properties of the protein. We identified the homologous region in the *Drosophila* genes by aligning the protein sequences with the *Anopheles aTepI* sequence (Blandin et al. 2004; Levashina et al. 2001). In none of the *Drosophila* genes did this region have an accelerated rate of protein evolution, suggesting that this is not a target of positive selection (Fig. 2).

The second approach that we used to estimate the K_a/K_s ratio was to align sequences from multiple species and fit a maximum likelihood model of codon substitution along the phylogenetic tree of those

species (Nielsen and Yang 1998). This analysis used unpublished data from the genome projects and there may be some errors in the sequences. We have assumed that any such errors will be equally likely at synonymous and nonsynonymous sites and will, therefore, not result in K_a being significantly higher than K_s . Different species were included for the different genes either because it was impossible to align the most variable regions of the sequences from distant relatives or because homologues could not be identified reliably in some species (i.e., there were no reciprocal best blast hits). To test whether the protein sequence of the different species has diverged under positive selection, we compared models of codon substitution where a proportion of sites was allowed to have $K_a/K_s > 1$ (Model M8) with models where all codons had $K_a/K_s \leq 1$ (Model M8A) (Swanson et al. 2003). In model M8A, the codons fell into either one of eight K_a/K_s categories that followed a beta distribution bounded between 0 and 1 or a ninth category where $K_a/K_s = 1$. Model M8 is identical except that the ninth category is free to vary above 1 (i.e., positive selection is allowed). In both *TepI* and *TepII*, model M8A was the better fit to the data (Table 2). Therefore, this analysis suggests that both of these genes are subject to positive selection.

Tep McDonald-Kreitman Test

An alternative approach to test whether the high K_a of *TepI* and *TepII* is the result of positive selection is to compare polymorphism and divergence at

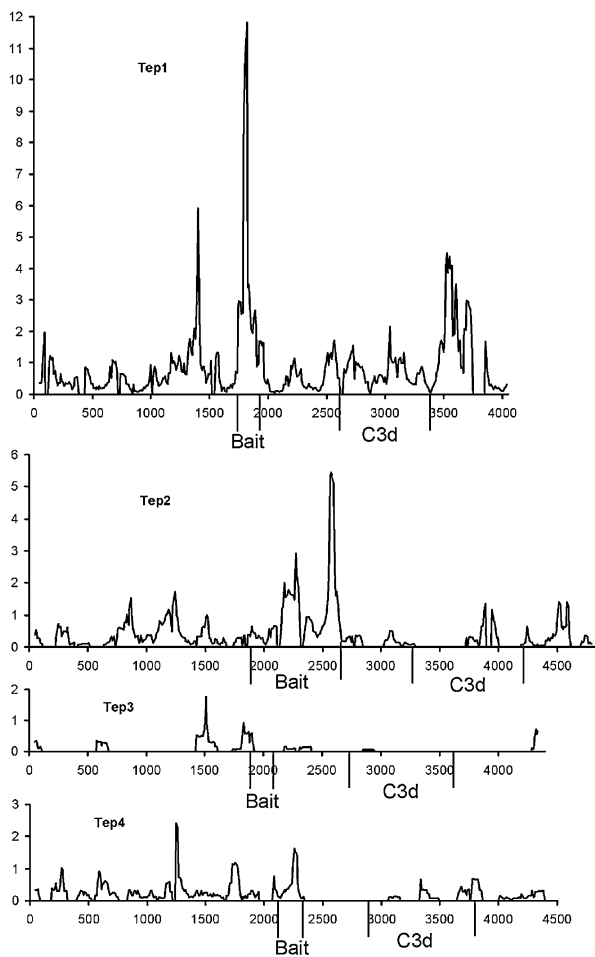

Fig. 2. Sliding window analysis of the K_a/K_s ratio along the entire coding sequence of the four *Tep* genes in *D. simulans* and *D. melanogaster*. The bait-like and C3d-like regions are marked. Window size = 100 bp; step size = 1 bp; K_a/K_s ratio estimated following Nei and Gojobori (1986).

synonymous and nonsynonymous sites. Under the neutral model, the ratio of synonymous:nonsynonymous polymorphic sites will be the same as the ratio of synonymous:nonsynonymous interspecific differences. The McDonald-Kreitman (1991) test simply compares these two ratios in a 2×2 contingency table. These ratios are significantly different in *TepI* (Table 3). This is the result of the large number of nonsynonymous substitutions that have occurred since *D. simulans* diverged from *D. melanogaster* (Table 1), as the synonymous divergence (Table 1) and θ_S/θ_R ratio (see below) of *TepI* are similar to those of the other two genes. This suggests that the significant McDonald-Kreitman test is caused by positive selection favoring changes to the TEPI amino acid sequence during the divergence of the two species. Interestingly, this test is significant even when the bait-like region is excluded from the analysis (Table 3), indicating that positive selection is not solely confined to this region of *TepI*. Using these data, it is possible to estimate that 71% of the amino

acid substitutions that have occurred were fixed by positive selection (Smith and Eyre-Walker 2002). This equates to positive selection fixing 121 nonsynonymous substitutions in the ~ 2.5 million years since these species diverged (Powell 1997). The McDonald-Kreitman test was not significant for *TepII* or *TepIV*.

Tep Polymorphism

The above analyses provide strong evidence that positive selection has acted on *TepI*. They also suggest that *TepII* may have evolved under positive selection. If this has been the result of directional selection causing recurrent selective sweeps, then the genetic diversity of these genes may have been reduced. Alternatively, some models of host-parasite coevolution predict that frequency dependent or diversifying selection may act on immune system molecules (Barrett 1988), which may result in increased genetic diversity at linked sites.

The synonymous site heterozygosity (Table 4) is similar to that of other genes in these species. For example, six other genes sampled from the same population had mean heterozygosities of $\pi_s = 0.013$ in *D. melanogaster* and $\pi_s = 0.033$ in *D. simulans* (*Dro1-6* [Jiggins and Kim 2005]). These estimates are similar to those reported for larger datasets from different populations by both Moriyama and Powell (1996) and Andolfatto (2001). The three genes have fairly high levels of nonsynonymous polymorphism relative to synonymous polymorphism (Table 4). This is most marked in *D. simulans*, where $\pi_s/\pi_a = 0.67$ in the bait region and $\pi_s/\pi_a = 4.42$ in the rest of the gene. This compares to a mean $\pi_s/\pi_a = 10.2$ across six other genes in this population (*Dro1-6* [Jiggins and Kim 2005]; similar estimates were obtained by Andolfatto (2001)).

The neutral model of molecular evolution predicts that polymorphism and divergence will be positively correlated across different genes or regions of genes. We did not formally compare levels of polymorphism and divergence among the three *Tep* genes, as they are found in regions of the genome with different rates of recombination (this can affect the nucleotide diversity [Begun and Aquadro 1992]). However, we did look for variation within each of the genes, and in *TepII* the polymorphism-to-divergence ratio was significantly heterogeneous using both the *D. simulans* and the *D. melanogaster* datasets (*D. melanogaster*, mean $G = 15.4$ [$p < 0.001$], number of runs = 183 [$p = 0.006$], K-S = 0.03 [$p = 0.03$]; *D. simulans*, mean $G = 6.49$ [$p < 0.03$], number of runs = 235 [$p = 0.22$], K-S = 0.04 [$p = 0.001$]). There was no significant heterogeneity in either *TepI* or *TepIV*.

Selection and demography can also alter the frequency of segregating sites within a population. We calculated Tajima's (1989) D , which reflects the

Table 2. Maximum likelihood test for codons with $K_a/K_s > 1$

Gene	Species ^a	Model	No. codons	K_a/K_s ^b	Proportion of sites ^b	Likelihood	$2\Delta l$	p
<i>TepI</i>	msye	M8A	1,361	1	0.46	-10,946.50	7.76	<0.01
		M8	1,361	188.81	0.005	-10,942.62		
<i>TepII</i> ^c	msye	M8A	1,529	1	0.23	-10,106.94	10.04	<0.005
		M8	1,529	2.05	0.09	-10,101.92		
<i>TepIII</i>	msyeapvo	M8A	1,432	1	0.01	-16,464.20	0	1
		M8	1,432	1.00	0.01	-16,464.20		
<i>TepIV</i>	msyeapv	M8A	1,458	1	0.04	-16,166.77	0	1
		M8	1,458	1.18	0.03	-16,166.78		

^a m, melanogaster; s, simulans; y, yakuba; e, erecta; a, annanasae; p, pseudoobscura; v, virilise; o, mojaveni;

^b Refers to the K_a/K_s category of sites in addition to β distribution (see text).

^c Excludes exon 9, which is too divergent to align.

Table 3. McDonald-Kreitman test on the *Tep* genes

Gene	Region	Fixed differences		Polymorphism, <i>melanogaster</i>			Polymorphism, <i>simulans</i>		
		Silent	Replace	Silent	Replace	p^a	Silent	Replace	p^a
<i>TepI</i>	Coding (bait)	2	18	0	0	—			
	Coding (nonbait)	70	153	10	7	0.03			
	All coding	72	171	10	7	0.03			
	Intron + coding	129	171	18	7	0.006			
<i>TepII</i>	Coding (bait exon 5)	3	3	0	0	n.s.	2	2	n.s.
	Coding (bait exon 6)	0	2	2	0	n.s.	1	1	n.s.
	Coding (bait exon 7)	3	9	1	0	n.s.	0	4	n.s.
	Coding (bait exon 8)	2	5	0	0	n.s.	0	2	n.s.
	Coding (bait exon 9)	9	26	1	3	n.s.	0	6	n.s.
	Coding (bait all exons)	17	45	4	3	n.s.	3	15	n.s.
	Coding (nonbait)	105	61	48	26	n.s.	57	37	n.s.
	All coding	122	106	52	29	n.s.	60	52	n.s.
Intron + coding	265	106	102	29	n.s.	129	52	n.s.	
<i>TepIV</i>	Coding (bait)	4	6	1	1	n.s.			
	Coding (nonbait)	59	29	14	14	n.s.			
	All coding	63	35	15	15	n.s.			
	Intron + coding	76	35	20	15	n.s.			

^a Two-tailed Fisher exact test. Dataset includes a single additional allele from the genome sequences of *D. simulans* and *D. melanogaster*.

frequency distribution of polymorphisms in the population, and Fay and Wu's (2000) H , which is a measure of the frequency of derived polymorphisms (Table 5). Of these statistics, only Fay and Wu's H for *TepI* was marginally significantly different from the null distribution generated by coalescent simulations conditioned on θ .

GNBP Interspecific Divergence

The ratio of nonsynonymous-to-synonymous substitutions (K_a/K_s) between the *D. melanogaster* and the *D. simulans* GNBP genes is similar to the genome average. In our sample of 4558 genes over 1 kb long, the *GNBP1*, *GNBP2*, and *GNBP3* K_a/K_s ratios fall in the 48th, 53rd, and 61st percentiles, respectively. In our sample of 64 immunity genes, the K_a/K_s ratios of CG12780, CG13422, *GNBP1*, *GNBP2*, and *GNBP3*

had the 16th, 28th, 37th, 41st, and 47th highest K_a/K_s ratios, respectively.

The highest amino acid divergence in the *GNBP* proteins is seen in the signal peptides (data not shown), which are cleaved from the mature proteins and probably never interact directly with pathogens. Therefore, this divergence is unlikely to be driven by parasite-induced positive selection. The carbohydrate-recognition and glucanase-homology domains are candidate sites of host-parasite coevolution, as they have been found to bind directly to various parasite-associated polysaccharides in the GNBP of other insects (Fabrick et al. 2004). However, both these domains are highly conserved (Table 1). Furthermore, sliding-window analyses along the gene did not reveal any high peaks of K_a/K_s (data not shown). We also repeated the maximum likelihood test for positive selection described above for the *Tep*

Table 4. Nucleotide diversity of the *Tep* and *GNBP* genes

Gene	Species	Region	Length (bp)	n^a	S^b	$\pi \times 10^2$	$\pi_a \times 10^2$	$\pi_s \times 10^2$	π_s/π_a	$\theta^d \times 10^2$
<i>TepI</i>	mel ^c	Coding (bait)	186	10	0	0.00	0.00	0.00		0.00
		Coding (not bait)	2671	10	17	0.21	0.11	0.53	4.82	0.23
		Intron	487	10	10	0.50				0.73
<i>TepII</i>	mel ^c	Coding (bait)	786	10	7	0.22	0.15	0.43	2.87	0.32
		Coding (not bait)	4050	10	74	0.69	0.33	1.86	5.64	0.66
		Intron	2045	10	58	1.00				1.00
<i>TepII</i>	sim ^f	Coding (bait)	753	8	18	0.82	0.89	0.60	0.67	0.92
		Coding (not bait)	3958	8	94	0.91	0.50	2.21	4.42	0.92
		Intron	1762	8	75	1.56				1.64
<i>TepIV</i>	mel ^c	Coding (bait)	186	10	2	0.23	0.16	0.47	2.94	0.41
		Coding (not bait)	3288	10	28	0.31	0.19	0.67	3.53	0.30
		Intron	288	10	6	0.82				0.74
<i>GNBP1</i>	mel ^c	Coding	1476	12	17	0.42	0.13	1.36	10.46	0.38
		Intron	292	12	6	0.62				0.68
<i>GNBP2</i>	mel ^c	Coding	1383	12	16	0.44	0.04	1.86	46.50	0.38
		Intron	503	12	11	1.02				0.84
<i>GNBP3</i>	mel ^c	Coding	1470	12	24	0.55	0.18	1.73	9.61	0.54
CG12780	mel ^c	Coding	300	12	4	0.37	0.19	0.92	4.84	0.44
CG13422	mel ^c	Coding	456	12	6	0.58	0.15	1.91	12.73	0.44

Analysis excludes positions with alignment gaps.

^a Number of alleles.

^b Number of segregating sites.

^d Watterson (1975) estimate of $4N_e\mu$.

^c *D. melanogaster*.

^f *D. simulans*.

Table 5. Summary statistics of the frequency spectrum of segregating sites of the *Tep* and *GNBP* genes for *D. melanogaster* (mel) and *D. simulans* (sim)

Gene	No. sites		Tajima's <i>D</i>		Fay & Wu's <i>H</i>	
	mel	sim	mel	sim	mel	sim
<i>TepI</i>	3347		-0.818		-5.600 ^a	
<i>TepII</i>	6807	6473	0.011	-0.213	-2.667	4.21
<i>TepIV</i>	3750		0.028		0.800	
<i>GNBP1</i>	1768		0.25		1.48	
<i>GNBP2</i>	1886		0.81		-1.97	
<i>GNBP3</i>	1470		0.08		-2.73	
CG12780	300		-0.54		0.09	
CG13422	456		1.25		-0.55	

^a $p < 0.05$. Analysis includes coding sequence and introns but excludes positions with alignment gaps.

genes. In none of the five *GNBP* genes did allowing a class of positively selected sites increase the likelihood of the model (data not shown).

GNBP Polymorphism

The nucleotide diversity of the *GNBP* genes is typical of that observed for *D. melanogaster* genes (Table 4). The level of polymorphism at nonsynonymous sites relative to synonymous sites is lower than was the case for the *Tep* genes and more typical of other *D. melanogaster* genes (Table 4). Summary statistics based on the frequency spectrum of polymorphisms are close to the neutral expectation, and none differed

significantly from null distributions generated by coalescent simulations conditioned on θ (Table 5).

The McDonald-Kreitman test also failed to give any evidence of positive selection acting on the *GNBP* genes (Table 6). We first conducted the test on each gene separately, and in all cases the synonymous:nonsynonymous ratio was the same for fixed differences between species and for polymorphic sites within species. We repeated the test separately for each of the different functional domains, summing the data across all five genes (Table 6). Again, the ratio did not differ significantly between intraspecific polymorphisms and interspecific divergence. There was significant heterogeneity in the polymorphism to

Table 6. McDonald-Kreitman test on *GNBP* genes

Gene	Region	Fixed differences		Polymorphic sites		<i>p</i>
		Synonymous	Nonsynonymous	Synonymous	Nonsynonymous	
<i>GNBP1</i>	All	43	10	12	5	n.s.
<i>GNBP2</i>	All	47	15	16	2	n.s.
<i>GNBP3</i>	All	34	11	16	8	n.s.
CG12780	All	9	7	3	1	n.s.
CG13422	All	12	6	6	2	n.s.
All	Signal	2	13	0	3	n.s.
All	CRD	42	16	19	3	n.s.
All	Link	48	11	17	4	n.s.
All	Glucanase	39	4	7	2	n.s.
All	end	14	5	10	6	n.s.
All	All	145	49	53	18	n.s.

Note. Polymorphism in *D. melanogaster*; divergence from *D. simulans*.

divergence ratio within *GNBP2* (mean $G=6.2$, $p=0.01$; number of runs = 35, $p=0.01$; K-S = 0.05, $p=0.03$). This test was not significant for any of the other four genes.

Discussion

The Evolution of Tep and GNBP Genes

The K_a/K_s ratio of *TepI* is among the highest 0.5% of genes in the *Drosophila* genome. Furthermore, there is strong evidence that this rapid evolution was driven by positive selection. First, the bait-like region has a K_a/K_s ratio that is significantly >1 . Second, a maximum likelihood analysis identified a proportion of codons as being positively selected. Finally, the McDonald-Kreitman test suggested that over 100 amino acid substitutions have been fixed by selection during the divergence of *D. simulans* and *D. melanogaster*. Therefore, it is likely that TEPI is continually adapting to novel parasite challenges.

Some immune-related genes in other species are highly polymorphic due to balancing selection maintaining variation. This is clearly not the case in *TepI*, which has slightly lower synonymous site diversity than is normal for other genes. However, *TepI* does not have a skewed frequency spectrum of polymorphisms or very low genetic diversity, as might be expected given that repeated selective sweeps have occurred in this gene. It is possible that the last selective sweep occurred sufficiently far in the past that the patterns of polymorphism have recovered to near the neutral equilibrium or that the small number of alleles means that analyses of the frequency spectrum of polymorphisms have little power (Ramos-Onsins and Rozas 2002; Simonsen et al. 1995). It is also possible that diversifying selection within or between populations is acting on *TepI*, which may have different effects on patterns of polymorphism to a simple selective sweep.

The extremely rapid evolution seen in *TepI* is not found in the other *Tep* genes. However, there is evidence that less intense positive selection is acting on *TepII*, although the data are less clear-cut than for *TepI*. In *TepII*, the maximum likelihood analysis strongly indicates that a proportion of codons is positively selected. Additionally, in the bait-like region $K_a/K_s = 1$, indicating either an absence of selective constraints or positive selection. However, despite its high nonsynonymous divergence, the McDonald-Kreitman test was not significant for this gene. This may result from a lack of statistical power or from diversifying selection increasing the level of nonsynonymous polymorphism. We found no evidence that TEPIV or TEPIII evolves under positive selection. Once functions of the different TEP molecules have been characterized, it may be possible to interpret the reasons that the different genes show different patterns of evolution.

We also conducted a similar set of analyses on the *Drosophila* GNBP. These genes showed little or no evidence of adaptive evolution. The only significant deviation from the neutral model was a heterogeneous polymorphism:divergence ratio in *GNBP2*. Although this may result from positive selection, variation in the mutation rate, the recombination rate, the strength of selection on synonymous sites (e.g., near splice sites), or the strength of background selection all could generate similar patterns (McDonald 1996, 1998). An unfortunate aspect of our data is that the GNBP and TEP datasets come from different populations (this was largely due to them being collected at different times), which makes it difficult to compare patterns of polymorphism directly. However, the differences we see are due to the higher interspecific divergence of the TEPs compared to the GNBP. Only about 0.2% of the divergence between *D. simulans* and *D. melanogaster* has occurred since the split of European and African populations (David and Capy 1988; Lachaise et al.

1988). Therefore, it is unlikely that the differences we see between GGBP and TEP evolution are the result of population specific effects and it is safe to conclude that the two gene families show different patterns of molecular evolution.

Why Does Natural Selection Act Differently on Different Immune Genes?

Evolutionary analyses such as this on immunity genes in a variety of animals have produced diverse results. Some genes contain ancient balanced polymorphisms, others show evidence of recurrent selective sweeps, and many simply evolve slowly under predominantly purifying selection. It is therefore of interest why different genes evolve in such different ways.

First, it is of interest whether receptor molecules in the innate immune system evolve differently than those in the acquired immune system do. None of the genes in this study showed any evidence of selection maintaining multiple alleles for long periods of evolutionary time, which is in agreement with studies of other *Drosophila* immune genes (Begun and Whitley 2000; Clark and Wang 1997; Jiggins and Hurst 2003; Jiggins and Kim 2005; Lazzaro and Clark 2003; Schlenke and Begun 2003). Although the ancient polymorphisms found in MHC genes are well known, this pattern has not been replicated in other components of the vertebrate immune system. Therefore, it is possible that ancient balanced polymorphisms are a peculiarity of MHC evolution, rather than a general difference between innate and acquired immunity. Therefore, models of host-parasite coevolution that predict the maintenance of host alleles over long periods of evolutionary time are unlikely to be generally applicable in animals.

It is still possible that diversifying selection may act on some immune genes but not maintain polymorphisms for long periods. Consistent with this, unusually high nonsynonymous heterozygosities have been reported for some *Drosophila* scavenger receptors (Lazzaro 2005). Some of our *Tep* datasets also had fairly high levels of nonsynonymous relative to synonymous polymorphism. However, this may simply reflect low selective constraints.

In *TepI* and *TepII*, natural selection has recurrently fixed advantageous nonsynonymous mutations. This pattern has been repeatedly observed both in other innate immune system genes (Schlenke and Begun 2003) and in acquired immune system genes. This is consistent with the predominant mode of host-parasite coevolution being a simple arms race between hosts and parasites, where novel adaptations and counter adaptations arise and are fixed within populations. Furthermore, this form of coevolution

does not appear to be restricted to highly specific acquired immune responses.

Second, another pattern to explain is why some *Drosophila* immunity genes evolve under positive selection while others do not. This study combined with previous work means that the molecular evolution of four different classes of molecules that bind to the surface of pathogens and illicit an immune response have been studied. The evolution of the TEPI and TEPII resembles patterns observed in *Drosophila* class C scavenger receptors (SR-Cs), which also evolve rapidly under positive selection (Lazzaro 2005). SR-Cs, like TEPs, bind to pathogens and are involved in their phagocytosis. The evolution of GGBPs resembles that of another class of recognition protein, the PGRPs (peptidoglycan recognition proteins), which evolve slowly under purifying selection (Jiggins and Hurst 2003). Some PGRPs have similar functions to GGBP1 and GGBP3, in that they bind to parasite polysaccharides and activate pathways that lead to the production of antimicrobial peptides (Leclerc and Reichhart 2004).

Why do the different groups of proteins have such different modes of evolution even though they all bind to the surface of the pathogens? Little et al. (2004) have suggested that the likelihood of host-parasite arms races will depend on the types of host and parasite molecules interacting. They propose that parasite polysaccharides have far less potential to evolve to evade the immune system than parasite proteins. Therefore, host-parasite coevolution is most likely to occur when host and parasite proteins interact (TEPs) than when host proteins interact with pathogen polysaccharides or glycoproteins (e.g., GGBPs and PGRPs). Scavenger receptors interact with a very broad range of ligands, including modified proteins (Krieger et al. 1993). A second hypothesis is that positive selection results from pathogens targeting particular molecules to suppress the host immune response (Begun and Whitley 2000). In this case, the positively selected molecules may have some unknown vulnerability to pathogen suppression. Finally, it may be that the positively selected molecules interact with specialist parasites, but PGRPs and GGBPs do not. Coevolutionary arms races will be much more likely between hosts and specialist parasites than between hosts and opportunistic infections. There are no known specialist bacterial or fungal pathogens of *D. melanogaster* that could coevolve with GGBPs or PGRPs. However, important targets of the cellular immune system are parasitoid wasps, and some of these are specialists on just a few *Drosophila* species. In particular, *TepI* is massively upregulated when flies are attacked by parasitoids and may be important in antiparasitoid defenses (Wertheim et al. 2005).

Finally, it is interesting to compare patterns of evolution seen in the same gene families across different arthropod taxa. A *Tep* gene from the crustacean *Daphnia* also evolves rapidly under positive selection (Little et al. 2004). This suggests that TEPs may be key sites of host-parasite coevolution in arthropods. In both *Drosophila* and *Daphnia Tep* genes, the bait-like region is a particular hotspot of positive selection. Unfortunately it is unknown whether insect TEPs are activated by parasite-derived proteases (as for α_2 -macroglobulin) or by host-derived proteases (as for complement proteins C3, C4, and C5). If the former is true, one hypothesis is that parasite proteases continually evolve new specificities that do not cleave the bait-like region, while the bait-like region changes its sequence to match the specificity of the proteases. If host proteases cleave the bait-like region, then it is possible that positive selection results from parasite adaptations to block the activation of the TEP proteins. Similar explanations have been proposed to account for the rapid evolution of other *Drosophila* immune system molecules (Begun and Whitley 2000).

The evolution of GNBP has been examined in both termites and *Daphnia* (Bulmer and Crozier 2005; Little et al. 2004). The *Daphnia* GNBP, like the *Drosophila* proteins, was under predominantly purifying selection. However, in termites two *GNBP* genes showed some evidence of positive selection. It is possible that living in colonies exposes termites to higher pathogen pressures and more host-specific pathogens, resulting in stronger selection acting on termite immunity genes. Consistent with this, some other components of the immune system are positively selected in termites but not *Drosophila* (Bulmer and Crozier 2004; Jiggins and Kim 2005).

Acknowledgments. This work was funded by a Wellcome Trust Research Career Development Fellowship to F.J. The fly lines were supplied by Penny Haddrill and originally collected by Peter Andolfatto and Bill Ballard. R. K. Wilson gave permission to use unpublished genome sequences and Dan Halligan generated the genome-wide K_a/K_s estimates.

References

- Altschul SF, Madden TL, Schaffer AA, Zhang JH, Zhang Z, Miller W, Lipman DJ (1997) Gapped BLAST and PSI-BLAST: a new generation of protein database search programs. *Nucleic Acids Res* 25:3389–3402
- Andolfatto P (2001) Contrasting patterns of X-linked and autosomal nucleotide variation in *Drosophila melanogaster* and *Drosophila simulans*. *Mol Biol Evol* 18:279–290
- Andolfatto P, Przeworski M (2000) A genome-wide departure from the standard neutral model in natural populations of *Drosophila*. *Genetics* 156:257–268
- Barrett JA (1988) Frequency-dependent selection in plant fungal interactions. *Philos Trans Roy Soc Lond Ser B Biol Sci* 319:473–483
- Begun DJ, Aquadro CF (1992) Levels of naturally occurring DNA polymorphism correlate with recombination rates in *D. melanogaster*. *Nature* 356:519–520
- Begun DJ, Whitley P (2000) Adaptive evolution of Relish, a *Drosophila* NF- κ B/I κ B protein. *Genetics* 154:1231–1238
- Bendtsen JD, Nielsen H, von Heijne G, Brunak S (2004) Improved prediction of signal peptides: SignalP 3.0. *J Mol Biol* 340:783–795
- Blandin S, Levashina EA (2004) Thioester-containing proteins and insect immunity. *Mol Immunol* 40:903–908
- Blandin S, Shiao SH, Moita LF, Janse CJ, Waters AP, Kafatos FC, Levashina EA (2004) Complement-like protein TEPI is a determinant of vectorial capacity in the malaria vector *Anopheles gambiae*. *Cell* 116:661–670
- Bulmer MS, Crozier RH (2004) Duplication and diversifying selection among termite antifungal peptides. *Mol Biol Evol* 21:2256–2264
- Bulmer MS, Crozier RH (2005) Variation in positive selection in termite GNBP and Relish. *Mol Biol Evol* 23:317–326
- Christophides GK, Zdobnov E, Barillas-Mury C, Birney E, Blandin S, Blass C, Brey NT, Collins FH, Danielli A, Dimopoulos G, Hetru C, Hoa N, Hoffmann JA, Kanzok SM, Letunic I, Levashina EA, Loukeris TG, Lycett G, Meister S, Michel K, Muller HM, Osta MA, Paskewitz SM, Reichhart JM, Rzhetsky A, Troxler L, Vernick KD, Vlachou D, Volz J, von Mering C, Xu JN, Zheng LB, Bork P, Kafatos FC (2002) Immunity-related genes and gene families in *Anopheles gambiae*. *Science* 298:159–165
- Clark AG, Wang L (1997) Molecular population genetics of *Drosophila* immune system genes. *Genetics* 147:713–724
- Comeron JM (1995) A method for estimating the numbers of synonymous and nonsynonymous substitutions per site. *J Mol Evol* 1:1152–1159
- David JR, Capy P (1988) Genetic variation of *Drosophila melanogaster* natural populations. *Trends Genet* 4:106–111
- De Gregorio E, Spellman PT, Rubin GM, Lemaitre B (2001) Genome-wide analysis of the *Drosophila* immune response by using oligonucleotide microarrays. *Proc Natl Acad Sci USA* 98:12590–12595
- Dimopoulos G, Richman A, Muller HM, Kafatos FC (1997) Molecular immune responses of the mosquito *Anopheles gambiae* to bacteria and malaria parasites. *Proc Natl Acad Sci USA* 94:11508–11513
- Fabrick JA, Baker JE, Kanost MR (2004) Innate immunity in a pyralid moth—functional evaluation of domains from a beta-1,3-glucan recognition protein. *J Biol Chem* 279:26605–26611
- Fay JC, Wu CI (2000) Hitchhiking under positive Darwinian selection. *Genetics* 155:1405–1413
- Ferrandon D, Imler J-L, Hoffmann JA (2004) Sensing infection in *Drosophila*: Toll and beyond. *Semin Immunol* 16:43
- Gobert V, Gottar M, Matskevich AA, Rutschmann S, Royet J, Belvin M, Hoffmann JA, Ferrandon D (2003) Dual activation of the *Drosophila* Toll pathway by two pattern recognition receptors. *Science* 302:2126–2130
- Hey J, Kliman RM (2002) Interactions between natural selection, recombination and gene density in the genes of *Drosophila*. *Genetics* 160:595–608
- Hughes AL, Nei M (1988) Pattern of nucleotide substitution at major histocompatibility complex class-I loci reveals overdominant selection. *Nature* 335:167–170
- Irving P, Troxler L, Heuer TS, Belvin M, Kopczynski C, Reichhart JM, Hoffmann JA, Hetru C (2001) A genome-wide analysis of immune responses in *Drosophila*. *Proc Natl Acad Sci USA* 98:15119–15124

- Jiggins FM, Hurst GDD (2003) The evolution of parasite recognition genes in the innate immune system: purifying selection on *Drosophila melanogaster* peptidoglycan recognition proteins. *J Mol Evol* 57:598–605
- Jiggins FM, Kim K-W (2005) The evolution of antifungal peptides in *Drosophila*. *Genetics* 171:1847–1859
- Kim Y-S, Ryu J-H, Han S-J, Choi K-H, Nam K-B, Jang I-H, Lemaitre B, Brey PT, Lee W-J (2000) Gram-negative Bacteria-binding protein, a pattern recognition receptor for lipopolysaccharide and beta-1,3-glucan that mediates the signaling for the induction of innate immune genes in *Drosophila melanogaster* Cells. *J Biol Chem* 275:32721–32727
- Ko WY, David RM, Akashi H (2003) Molecular phylogeny of the *Drosophila melanogaster* species subgroup. *J Mol Evol* 57:562–573
- Krieger M, Acton S, Ashkenas J, Pearson A, Penman M, Resnick D (1993) Molecular flypaper, host defense, and atherosclerosis. Structure, binding properties, and functions of macrophage scavenger receptors. *J Biol Chem* 268:4569–4572
- Lachaise D, Cariou ML, David JR, Lemeunier F, Tsacas L, Ashburner M (1988) Historical biogeography of the *Drosophila melanogaster* species subgroup. *Evol Biol* 22:159–225
- Lagueux M, Perrodou E, Levashina EA, Capovilla M, Hoffmann JA (2000) Constitutive expression of a complement-like protein in Toll and JAK gain-of-function mutants of *Drosophila*. *Proc Natl Acad Sci USA* 97:11427–11432
- Lazzaro BP (2005) Elevated polymorphism and divergence in the class C scavenger receptors of *Drosophila melanogaster* and *D. simulans*. *Genetics* 169:2023–2034
- Lazzaro BP, Clark AG (2003) Molecular population genetics of inducible antibacterial peptide genes in *Drosophila melanogaster*. *Mol Biol Evol* 20:914–923
- Leclerc V, Reichhart JM (2004) The immune response of *Drosophila melanogaster*. *Immunol Rev* 198:59–71
- Lee W-J, Lee J-D, Kravchenko VV, Ulevitch RJ, Brey PT (1996) Purification and molecular cloning of an inducible Gram-negative bacteria-binding protein from the silkworm, *Bombyx mori*. *Proc Natl Acad Sci USA* 93:7888–7893
- Levashina EA, Moita LF, Blandin S, Vriend G, Lagueux M, Kafatos FC (2001) Conserved role of a complement-like protein in phagocytosis revealed by dsRNA knockout in cultured cells of the mosquito, *Anopheles gambiae*. *Cell* 104:709
- Little TJ, Colbourne JK, Crease TJ (2004) Molecular evolution of *Daphnia* immunity genes: polymorphism in a gram-negative binding protein gene and an alpha-2-macroglobulin gene. *J Mol Evol* 59:498–506
- Marais G, Mouchiroud D, Duret L (2003) Neutral effect of recombination on base composition in *Drosophila*. *Genet Res* 81:79–87
- McDonald JH (1996) Detecting non-neutral heterogeneity across a region of DNA sequence in the ratio of polymorphism to divergence. *Mol Biol Evol* 13:253–260
- McDonald JH (1998) Improved tests for heterogeneity across a region of DNA sequence in the ratio of polymorphism to divergence. *Mol Biol Evol* 15:377–384
- McDonald JH, Kreitman M (1991) Adaptive protein evolution at the *Adh* locus in *Drosophila*. *Nature* 351:652–654
- Medzhitov R, Janeway CA (1997) Innate immunity: the virtues of a nonclonal system of recognition. *Cell* 91:295–298
- Moriyama EN, Powell JR (1996) Intraspecific nuclear DNA variation in *Drosophila*. *Mol Biol Evol* 13:261–277
- Nei M, Gojobori T (1986) Simple methods for estimating the numbers of synonymous and nonsynonymous nucleotide substitutions. *Mol Biol Evol* 3:418–426
- Nielsen R, Yang Z (1998) Likelihood models for detecting positively selected amino acid sites and applications to the HIV-1 envelope gene. *Genetics* 148:929–936
- Ochiai M, Ashida M (2000) A pattern-recognition protein for beta-1,3-glucan—the binding domain and the cDNA cloning of beta-1,3-glucan recognition protein from the silkworm, *Bombyx mori*. *J Biol Chem* 275:4995–5002
- Powell JR (1997) Progress and prospects in evolutionary biology: The *Drosophila* model. Oxford University Press, Oxford
- Ramos-Onsins SE, Rozas J (2002) Statistical properties of new neutrality tests against population growth. *Mol Biol Evol* 19:2092–2100
- Rozas J, Rozas R (1999) DnaSP version 3: an integrated program for molecular population genetics and molecular evolution analysis. *Bioinformatics* 15:174–175
- Schlenke TA, Begun DJ (2003) Natural selection drives *Drosophila* immune system evolution. *Genetics* 164:1471–1480
- Simonsen KL, Churchill GA, Aquadro CF (1995) Properties of statistical tests of neutrality for DNA polymorphism data. *Genetics* 141:413–429
- Smith DR (2004) *Drosophila ananassae* and *D. erecta* whole-genome shotgun reads Agencourt Bioscience Corp., Beverly, MA
- Smith NGC, Eyre-Walker A (2002) Adaptive protein evolution in *Drosophila*. *Nature* 415:1022
- Sottrup-Jensen L, Sand O, Kristensen L, Fey GH (1989) The alpha-macroglobulin bait region. Sequence diversity and localization of cleavage sites for proteinases in five mammalian alpha-macroglobulins. *J Biol Chem* 264:15781–15789
- Stroschein-Stevenson SL, Foley E, Farrell PH, Johnson AD (2006) Identification of *Drosophila* gene products required for phagocytosis of *Candida albicans*. *PLoS Biol* 4:87–99
- Swanson WJ, Nielsen R, Yang Q (2003) Pervasive Adaptive evolution in mammalian fertilization proteins. *Mol Biol Evol* 20:18–20
- Tajima F (1989) Statistical method for testing the neutral mutation hypothesis by DNA polymorphism. *Genetics* 123:585–595
- Tanaka T, Nei M (1989) Positive Darwinian selection observed at the variable-region genes of immunoglobulins. *Mol Biol Evol* 6:447–459
- Watterson GA (1975) On the number of segregating sites in models without recombination. *Theor Popul Biol* 7:256–276
- Wertheim B, Kraaijeveld AR, Schuster E, Blanc E, Hopkins M, Pletcher SD, Strand MR, Partridge L, Godfray HCJ (2005) Genome-wide gene expression in response to parasitoid attack in *Drosophila*. *Genome Biol* 6:R94
- Wilson RK (2004) *D. yakuba* whole-genome shotgun sequence Washington University Genome Sequencing Center, St. Louis, MO
- Yang Z (1997) PAML: a program package for phylogenetic analysis by maximum likelihood. *Comput Appl Biosci* 13:555–556